

2 TON ROADWAY

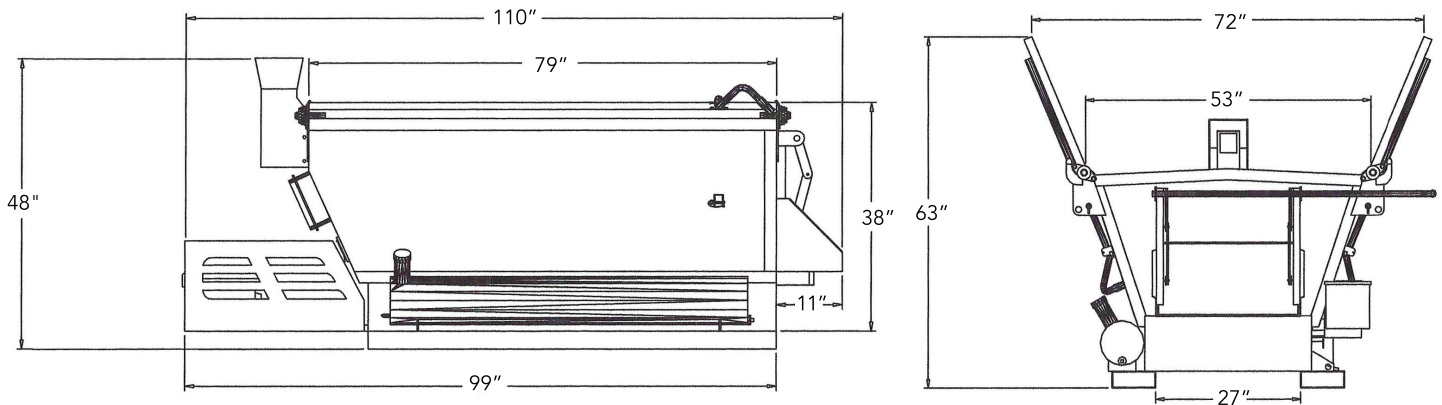

Model	Roadway
Type	2 Ton Slip In
Capacity	4,000 lbs of material
Base Weight	1,600 lbs
Weight loaded with material	5,600 lbs
Fuel Source	Diesel
Fuel Capacity	12.5 gallons
Burner Type	105,000 BTU Diesel Beckett burner w/electronic spark ignite
Number of burners	1
Unloading door	Insulated, guillotine-style, 12"x26"
Loading doors	Manual
	79"L x 26"W (each)
Hopper Opening	74.5" L x 47.25" W
Width	57"
Length	110"
Height	46"
Construction	Triple wall constructed and fully insulated – air jacketed
	Hopper floor 7 gauge
	Heated floor and hopper walls
	10 gauge capping channel
	Corner molding (adds structural integrity to the hopper)
	All wiring external to hopper
Paint	Blasted and painted with two coats of epoxy primer and urethane finish
Asphalt repair areas	9'X9'X4" depth (80 potholes 1'x1'x4"depth)
	Limited option availability
Warranty	Two year machine

Falcon Asphalt Repair Equipment

2600 W. Salzburg Rd.
 Freeland, MI 48623
 sales@falconrme.com

Phone: (989) 495-9332
 Fax: (989) 495-9342
 www.falconrme.com

WWW.FALCONRME.COM



2 TON ROADWAY

STANDARD:

- Battery charger package
- Automatic temperature control
- VIP Technology
- One piece ceramic combustion chamber (diesel)
- 92% fuel efficiency (diesel)
- 12 volt deep cycle battery
- Heated shoveling platform
- Conspicuity tape

OPTIONS:

- 7-day timer
- Slow moving vehicle decals
- 5-lb fire extinguisher
- Limited option availability

All Falcon machines are built with pride in Midland, Michigan. Falcon hot boxes and recyclers give you unparalleled **versatility**. You can **transport cold mix**, keeping it warm during the winter months and making it easier to work with; you can **transport hot mix and keep it hot all day**; and you can **hold hot mix overnight**, keeping it warm for up to 48 hours. You can also **reclaim unused hot mix**, eliminating the waste of good material, and you can **recycle asphalt chunks and millings**. All of this makes Falcon the most versatile machine you can buy for pavement preservation.

THE FALCON ADVANTAGE



Large Unloading Door
For Easy Access

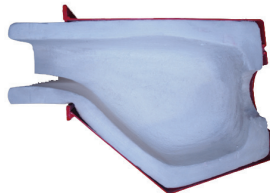

Patented Heat
Management System



Patented VIP - Low
Voltage Shutdown

Falcon Asphalt Repair Equipment
2600 W. Salzburg Rd.
Freeland, MI 48623
sales@falconrme.com

Phone: (989) 495-9332
Fax: (989) 495-9342
www.falconrme.com

WWW.FALCONRME.COM