

4 TON PATCH TRUCK

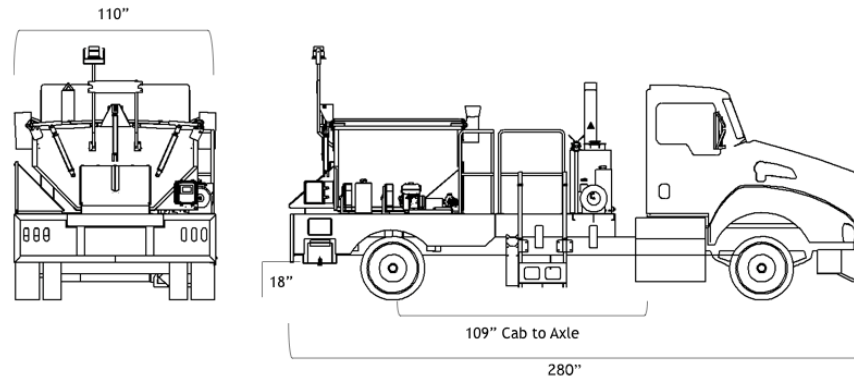

Type	4 Ton Patch Truck
Capacity	8,000 lbs of material
GVWR	25,999 lbs
Fuel Source	Diesel
Burner Type	105,000 BTU Diesel Beckett burner w/ electronic spark ignition
Number of Burners	1
Unloading Door	18" H x 33" W
Loading Doors	Hydraulic 64" L x 88" W
Hopper Opening	106" – doors open
Width	110"
Length	280"
Height	123"
Cab to Axle	109" L
Ground Clearance	18"
Hopper Construction	<ul style="list-style-type: none"> • Triple wall insulated – air jacketed • 10 gauge capping channel and corner molding Hopper floor ¼" steel • Wiring is external to hopper
Paint	Blasted and painted with two coats of epoxy primer and urethane finish
Asphalt repair areas	9'x9'x4" depth (80 potholes 1'x1'x4" depth)

Minimum Truck Requirements:

Truck Class	Class 6
Maximum Wheel Base	194"
Minimum Wheel Base	182"
Maximum Cab to Axle	120"
Minimum Cab to Axle	108"
Batteries	Dual
Recommended Trucks	Ford F750, Freightliner MD6 106, Hino 268A, International MV, Kenworth T270, Mack MD6, Peterbuilt 536/7

Falcon Asphalt Repair Equipment
 2600 W. Salzburg Rd.
 Freeland, MI 48623
 sales@falconrme.com

Phone: (989) 495-9332
 Fax: (989) 495-9342
 www.falconrme.com

WWW.FALCONRME.COM



4 TON PATCH TRUCK

STANDARD:

- Single diesel burner
- One-piece ceramic combustion chamber
- Hydraulic loading and unloading doors
- Battery charger package
- Dumping frame
- Onboard hydraulics – including PTO
- Tool box – lane side
- Smart Control package including: voltmeter, VIP, 7-day timer, temperature gauge, hour meter, and diagnostic package
- Additional loading door lever near truck cab
- Overnight heat
- Chassis mounted
- Shovel apron
- Tool holders
- Skirting kit
- Hopper access platform
- Platform railings
- Ladder – 2 step
- Pylon holders
- Federal Signal lighting kit, including: stop/tail/turn/reverse, markers, arrow board, work lights for hopper, platform and rear of machine, and beacon
- Backup camera
- Fire extinguisher
- DOT compliance kit: flares, triangles, etc.

OPTIONS:

- Propane burner with frame-mounted saddle tanks, in lieu of diesel
- 50-gallon tack tank with reversing pump
- Spray system for tack tank with hose reel
- Washdown system with hose reel
- Torch with bracket for 20lb tank and hose reel
- Hydraulic hoist with tray for plate compactor
- Bomag BVP18/45-2W
- Vibco GR3200
- Hammer bracket, mounted on hoist
- Hammer holster, mounted in rear bumper
- Spoils bin
- Asphalt chute, removable
- Solvent tank
- Grill mounted flashers
- Headache rack
- Contact Falcon for information on options for air compressors and air tools.

The Falcon patch truck is easy to operate. The gravity dump system, with no auger or conveyor belt, eliminates moving parts inside the hopper. In addition to reduced maintenance and repair costs, eliminating the auger/conveyor means faster material delivery and reduced overall vehicle weight (25,999 GVWR). No CDL is required to operate this patcher while still carrying a 4-ton payload.

Standard features include the Falcon-patented heat management system with a 5-year maintenance-free combustion chamber, a large material unloading door for easy access and fast material delivery, the Falcon-patented VIP system to eliminate damage from low voltage, a durable and reliable hydraulic dump system, and a commitment to curbside safety and easy access work surfaces.

THE FALCON ADVANTAGE



Large Material Unloading Door for Easy Access

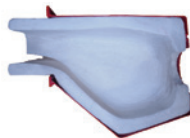

Patented Heat Management System



Platform For Safe, Easy Hopper Access



Patented VIP - Low Voltage Shutdown

Falcon Asphalt Repair Equipment
2600 W. Salzburg Rd.
Freeland, MI 48623
sales@falconrme.com

Phone: (989) 495-9332
Fax: (989) 495-9342
www.falconrme.com

WWW.FALCONRME.COM